

QCBOX

POWER AMPLIFIER, SWITCHING AND TESTING BOX

MODEL 5



USER'S MANUAL



© Copyright 1991-2009 by AUDIOMATICA SRL

All Rights Reserved

Edition 1.1, September 2009

IBM is a registered trademark of International Business Machines Corporation.
Windows is a registered trademark of Microsoft Corporation.

CONTENTS

1 - THE QCBOX MODEL 5 POWER AMPLIFIER, SWITCHING AND TESTING BOX ..	3
2 - TECHNICAL SPECIFICATIONS	4
3 - GENERAL CONDITIONS AND WARRANTY	5
4 - INTERNAL FUNCTIONAL DIAGRAM	6
5 - BASIC CONNECTIONS	7
6 - DEFAULT INTERNAL SETTINGS	8
7 - USB DRIVER INSTALLATION	9
8 - SOFTWARE CONTROL	11
9 - CALIBRATING SOFTWARE	12
10 - CONNETTING EXTERNAL HARDWARE.....	13
11 - CONNECTING A FOOT PEDAL SWITCH	13
12 - RACK MOUNT ASSEMBLY	13
13 - INTERNAL SETTINGS AND TROUBLESHOOTING	14

1 - THE QCBOX MODEL 5 POWER AMPLIFIER, SWITCHING AND TESTING BOX



The QCBOX Model 5 power amplifier, switching and testing box is of invaluable help in everyday laboratory use and when configuring an automatic or manual quality control setup.

The QCBOX Model 5 has an ultraslim design, enhanced features as USB connection to the PC and DC measuring capabilities with respect to its predecessor model 4, increased power (50W@8Ohm) with respect to its predecessors Model 1, 2 & 3 and wide range AC (90÷240V) power supply. The power amplifier output current is limited under software control.

Its main feature is the possibility of **internal switching**, under software control, that permits the measurement of the impedance and frequency response of the loudspeaker (or D.U.T.) connected to its output sockets without changing the loudspeaker (or D.U.T.) wiring; it is also possible to choose one among four inputs for the response measurements; the internal switching is controlled via a USB port of the PC. The inputs 3 and 4 can be also configured to measure DC voltages with range $\pm 2.5V$ and $\pm 5V$ respectively. More than one unit can be used to route more than four channels.

An internal software controlled voltage generator can superimpose a DC voltage ($\pm 20V$) to the amplifier voltage output, allowing for loudspeaker large signal parameters measurement.

A dedicated output, ISENSE, allows impedance measurements in constant voltage mode as well voice coil current distortion analysis. The ISENSE DC current is measured in a range $\pm 2.25A$.

A dedicated input, PEDAL IN, permits an external foot pedal switch or TTL signal to be connected and trigger QC operations.

A DB25 connector on the rear panel feature 5 digital IN and 6 digital OUT.

2 - TECHNICAL SPECIFICATIONS

Inputs:	Four line/microphone inputs with selectable phantom power supply (0÷24V software controlled) TTL pedal input (RCA connector)
Digital I/O:	5 digital inputs (DB25 connector) 6 digital outputs (DB25 connector)
Power output stage:	50W (80hm) power amplifier (26dB gain) with current sensing and software controlled current limiter Capability of superimposing a DC voltage ($\pm 20V$)
THD (@1 kHz):	0.004 %
Functions:	USB controlled internal switches for impedance measurements Isense DC current measurement $\pm 2.25A$ DC IN measurement (IN 3 range $\pm 2.5V$, IN 4 range $\pm 5V$)
Dimensions:	23(w)x23(d)x4(h)cm
Weight:	1.4kg
Power supply:	150W 90÷240VAC

3 - GENERAL CONDITIONS AND WARRANTY

THANKS

Thankyou for purchasing your QCBox Model 5. We hope that your experiences using QCBox Model 5 will be both productive and satisfying.

CUSTOMER SUPPORT

Audiomatica is committed to supporting the use of the QCBox Model 5, and to that end, offers direct support to end users. Our users all around the world can contact us directly regarding technical problems, bug reports, or suggestions for future software enhancements. You can call, fax or write to us at:

AUDIOMATICA SRL
VIA MANFREDI 12
50136 FLORENCE, ITALY
PHONE: +39-055-6599036
FAX: +39-055-6503772

AUDIOMATICA ON-LINE

For any inquiry and to know the latest news about the QCBox Model 5 and other Audiomatica's products we are on the Internet to help you:

AUDIOMATICA website: www.audiomatica.com
E-MAIL: info@audiomatica.com

AUDIOMATICA'S WARRANTY

Audiomatica warrants the QCBox Model 5 against physical defects for a period of **one year** following the original retail purchase of this product. In the first instance, please contact your local dealer in case of service needs. You can also contact us directly as outlined above, or refer to other qualified personnel.

WARNINGS AND LIMITATIONS OF LIABILITY

Audiomatica will not assume liability for damage or injury due to user servicing or misuse of our product. Audiomatica will not extend warranty coverage for damage of the QCBox Model 5 caused by misuse or physical damage. Audiomatica will not assume liability for the recovery of lost programs or data. The user must assume responsibility for the quality, performance and the fitness of Audiomatica software and hardware for use in professional production activities.

The CLIO SYSTEM and AUDIOMATICA are registered trademarks of Audiomatica SRL.

4 - INTERNAL FUNCTIONAL DIAGRAM

The first diagram shows us the unit set for **impedance** measurements (in **Internal Mode** referring to CLIO software, see chapter 13 of the User's Manual); in this situation the power amplifier and inputs are disconnected while the speaker load is presented in parallel with CLIO's input and output; this method of impedance measurement relies on the precise knowledge of the analyzer's output impedance and stimulates the D.U.T with signals of small amplitude.

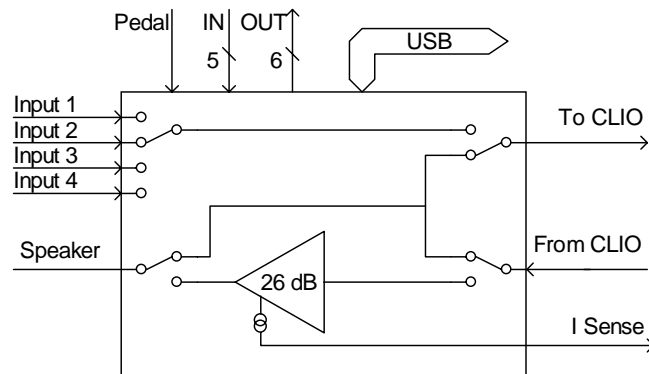

Internal connections for impedance measurements (Internal Mode)

The second diagram shows us the unit set for **frequency response** measurements; in this situation CLIO's output is fed to the power amplifier that drives the speaker under test while one among four inputs is directed to CLIO's input.

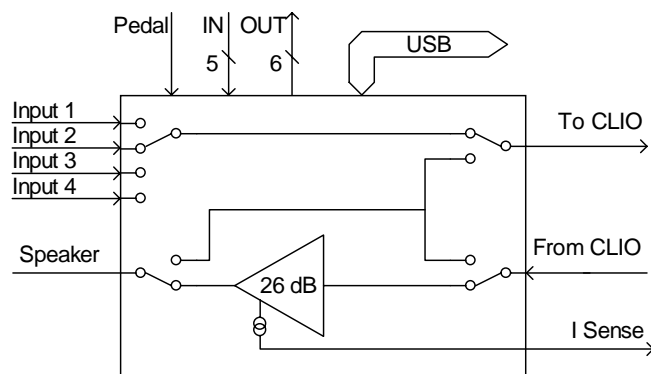

Internal connections for frequency response measurements

NOTE: when the unit is set for frequency response measurements it is possible to measure the current flowing in the D.U.T. through the **ISENSE** output; this permits impedance measurements stimulating the D.U.T. with signals of variable amplitude up to the amplifier's maximum power or voltage. Refer to chapter 13 of the CLIO User's Manual.

5 - BASIC CONNECTIONS

The following diagram shows the basic connections needed to operate the unit.

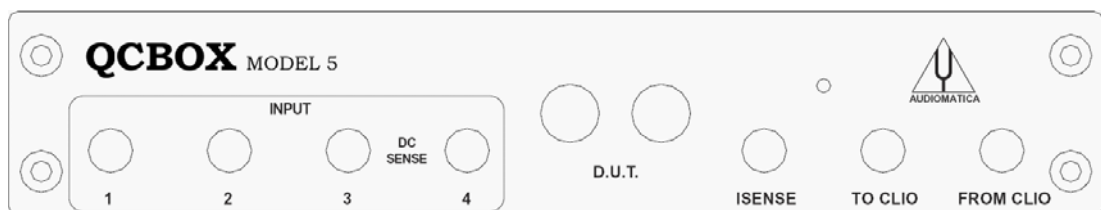
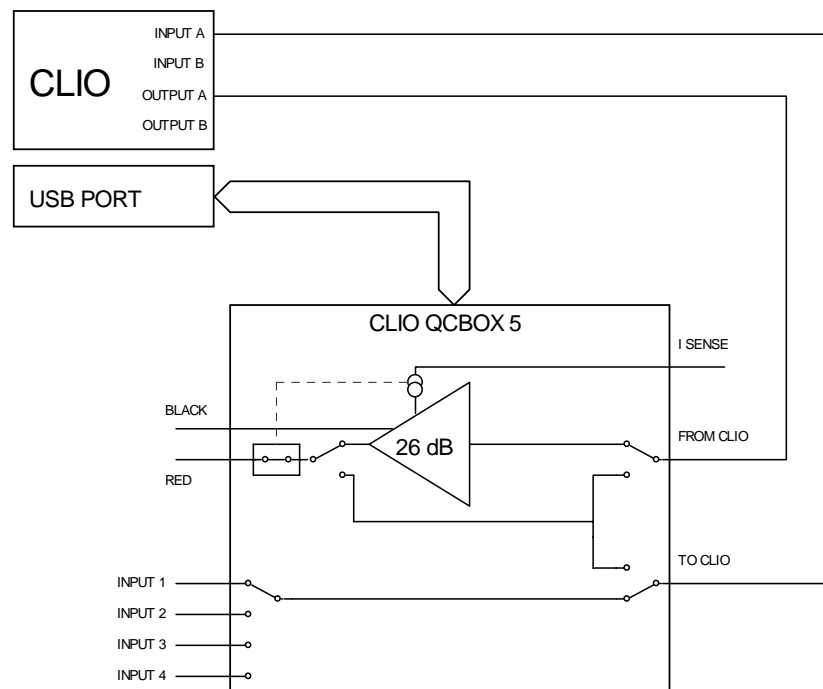

Please connect (referring to the front panel):

- 1) A pin-to-pin cable from the "From CLIO" RCA plug to CLIO's output.
- 2) A pin-to-pin cable from the "To CLIO" RCA plug to CLIO's input.

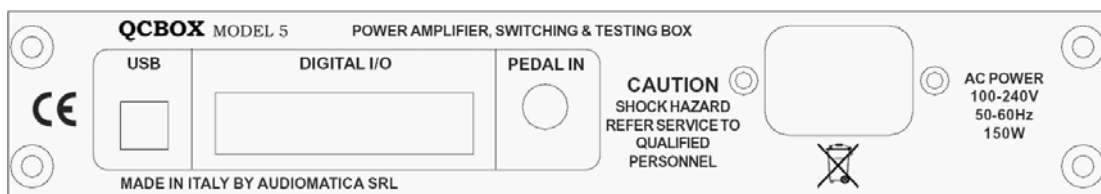

Please connect (referring to the rear panel):

- 3) An USB cable from the USB plug to a free PC USB port.
- 4) A standard IEC AC cord in the AC Power receptacle.

There is no mains switch. Now you can plug the AC cord in the wall outlet and verify the lighting of the front panel LED.

6 - DEFAULT INTERNAL SETTINGS

The QCBox Model 5 can be operated also if the USB cable is not connected to the PC.

In this particular case, when software control doesn't take place, the unit operates in the following mode:

Internal setting: frequency response.

Input: enabled input 1.

I SENSE: enabled.

Current protection limiter: 2 A.

7 - USB DRIVER INSTALLATION

When connecting the USB cable to the PC and the QC Box it may be requested by the operating system to install a device driver.

Install driver under Windows XP



You will be prompted with the dialog boxes in next figure. Select 'No. Not this time' and then select 'Install from a list or specific location (Advanced)'.
'

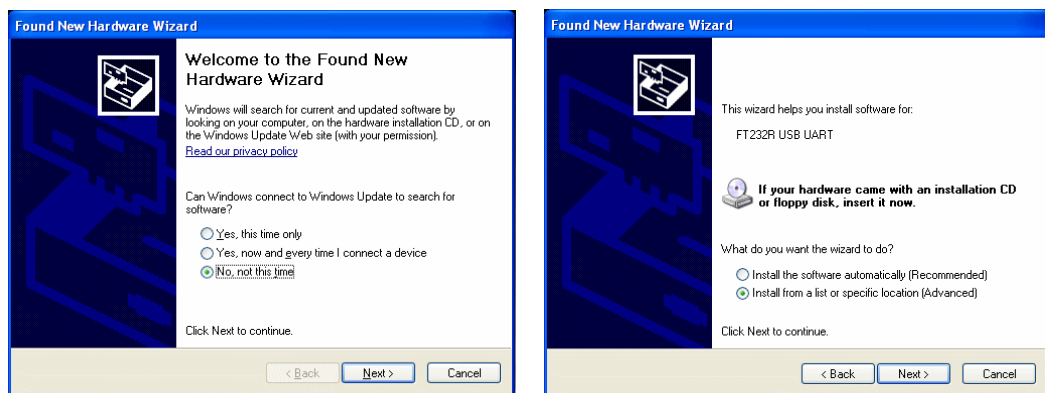

At the successive prompt Select 'Search for the best driver in these locations' and press the 'Browse...' button. Choose the '**USB Drivers**' folder inside the CLIO CD-ROM .It will be installed the **USB Serial Converter**.

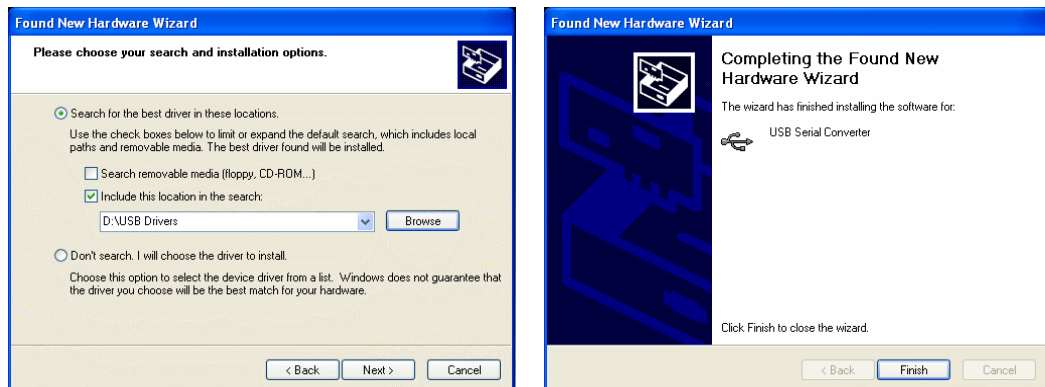

You will be prompted again to install the second USB device: repeat the same procedure to install the **USB Serial Port**.

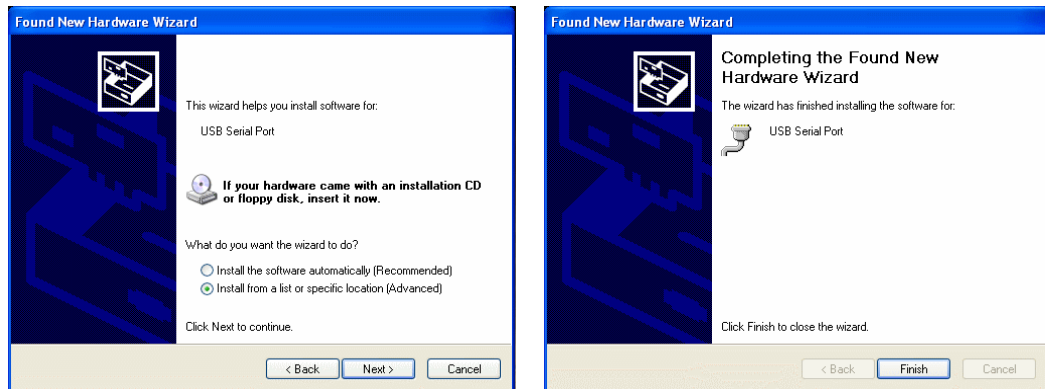

Windows drivers installation is now finished and your QCBOX Model 5 system ready to be used.

Install driver under Windows Vista

You will be prompted with the dialog box in next figure. Select 'Locate and Install Driver'.

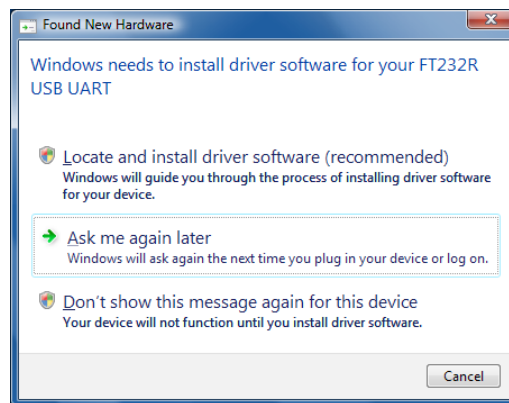

Vista will connect to the Windows Update site trying to download the driver. If it fails or if an internet connection is not available it will ask for a device driver CD.

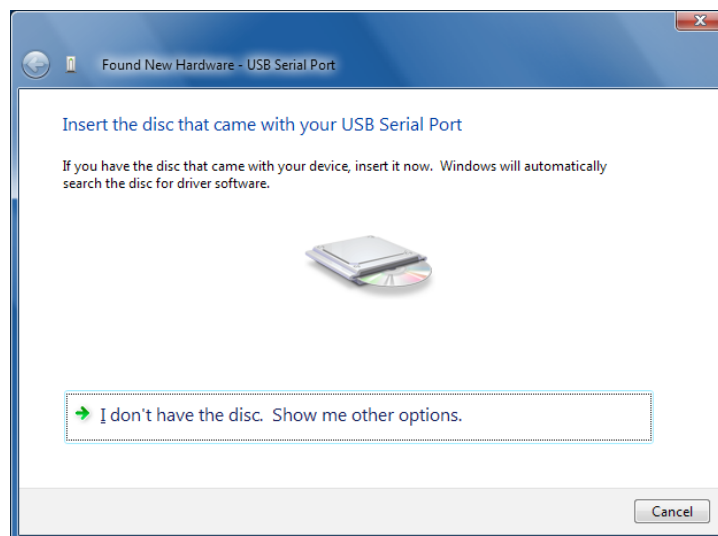

Please insert the QCBox 5 CD rom, the drivers will be automatically found and installed.

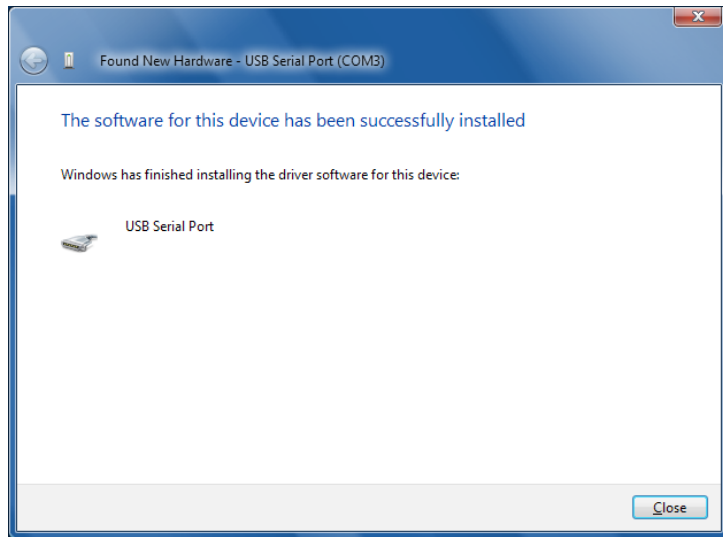

Windows drivers installation is now finished and your QCBOX Model 5 system ready to be used.

8 - SOFTWARE CONTROL

It is possible to control the QCBOX Model 5 from the CLIO 8 software.

Run CLIO 8, then click on the External Hardware Button (or simply press **Shift-F4**).

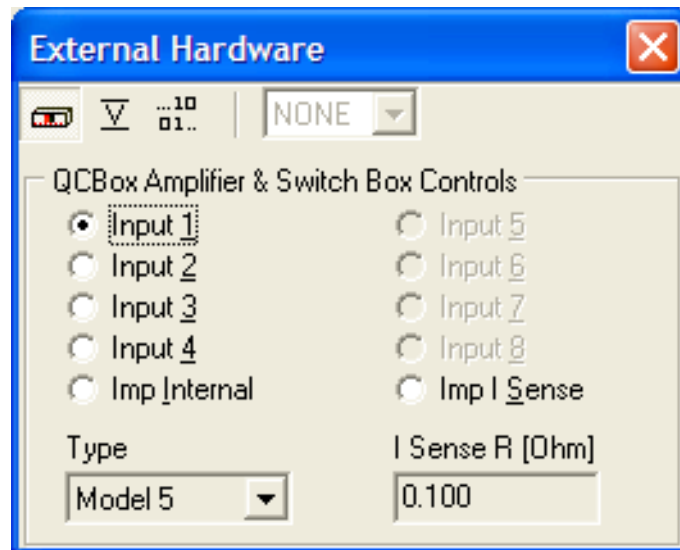

Choose Model 5 in the 'Type' drop down. The control should be active; an acoustic confirmation should come from the internal relays, you should hear them clicking when changing inputs.

Please refer to the CLIO User's Manual for executing frequency response and impedance measurements.

Pressing the  button gives access to the QCBOX MODEL 5 advanced features:

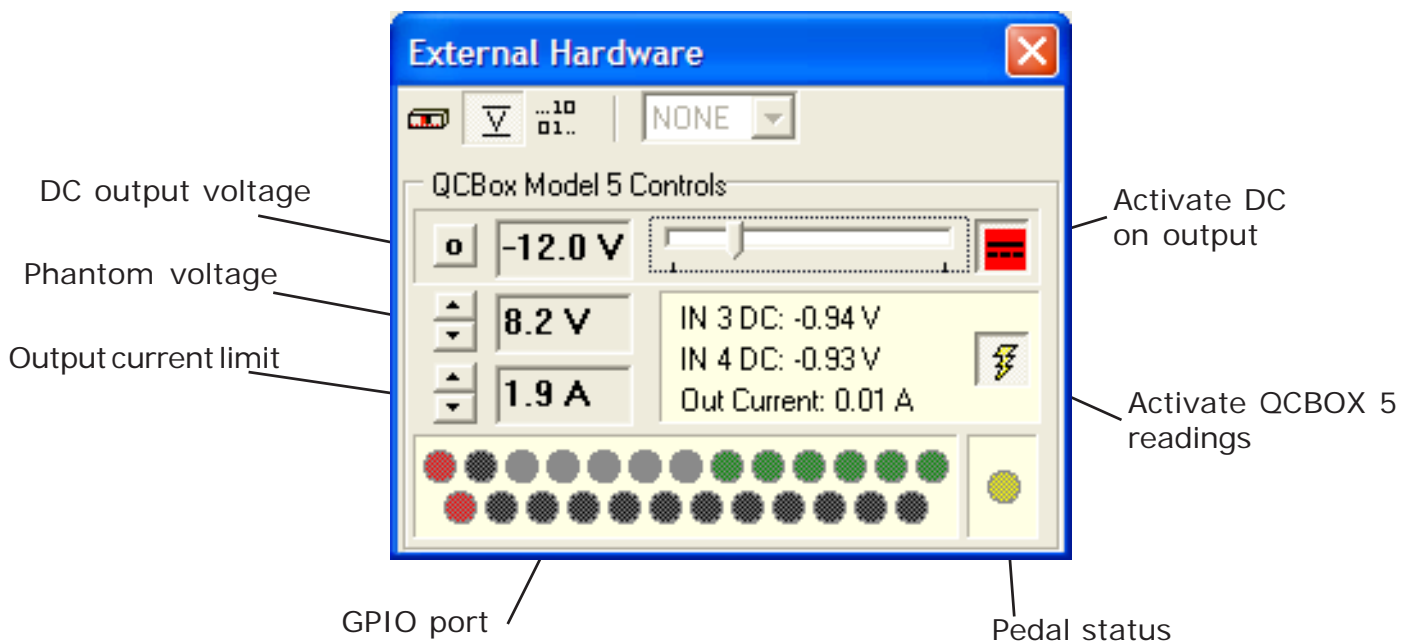

Using this panel is possible to choose the DC output voltage, the phantom voltage, the output current limiter. The GPIO port can be write simply by clicking on the output bits.

9 - CALIBRATING SOFTWARE

It is possible to calibrate the CLIO 8 software to obtain maximum precision when executing current sensing measurement. The calibration relies on the input of the correct sensing resistor value (**I Sense R**) in the External Hardware panel.

Inside the unit there is a sensing resistor of nominal value of 0.1 Ohm; as it is rather difficult to maintain such a low value under strict production control the software allows for the input of its value. The calibration relies on an impedance measurement of a precision resistor of known value.

Please enter the value of 0.1 Ohm; this will give you reasonable precision during measurements even in absence of the calibration described hereafter.

If you want to proceed with the calibration:

- 1) Take a resistor of known value (in the range 10 to 22 Ohm); assume, for example, a known resistor of 10 Ohm
- 2) Connect the resistor directly to the output (D.U.T.) socket of the QCBox (don't use connecting cables)
- 3) Simply perform an impedance measurement (refer to chapter 13 of CLIOwin User's Manual)
- 4) Read the value of its modulus at 1kHz; assume you read 9.5 Ohm
- 5) Multiply 0.1 by 1.05 (10/9.5) to obtain 0.105
- 6) Input this new value
- 7) Verify calibration with a new impedance measurement

13 - INTERNAL SETTINGS AND TROUBLESHOOTING

If you want to make one of the possible internal settings **disconnect the unit from the mains power** and then carefully open the unit; locate SW2 from the figure below and make the appropriate selection. It is possible, using the dip switch SW2, to select a phantom power supply on each input separately. When a switch is ON the phantom power is present at that input.

Jumper J17 - If present input 3 is DC coupled

Jumper J18 - If present input 4 is DC coupled

Jumper J21 - If present the power amplifier input is DC coupled

Default factory settings are phantom power on inputs 1 and 2, input 3 and 4 DC coupled and power amplifier AC coupled (J21 not present).

