

CLIO to EASE Converter

Preliminary User Guide – v.0.1.0.4

This software converts polar measurements sets (horizontal and vertical) “.mls” made with CLIO measurement system to “.xhn” EASE tabular data ASCII files for directivity. The horizontal and vertical measurements sets must be auto-named in the CLIO format “<filename> <angle*100>.mls”, the reference angles for the measurements must be in accordance with figure:

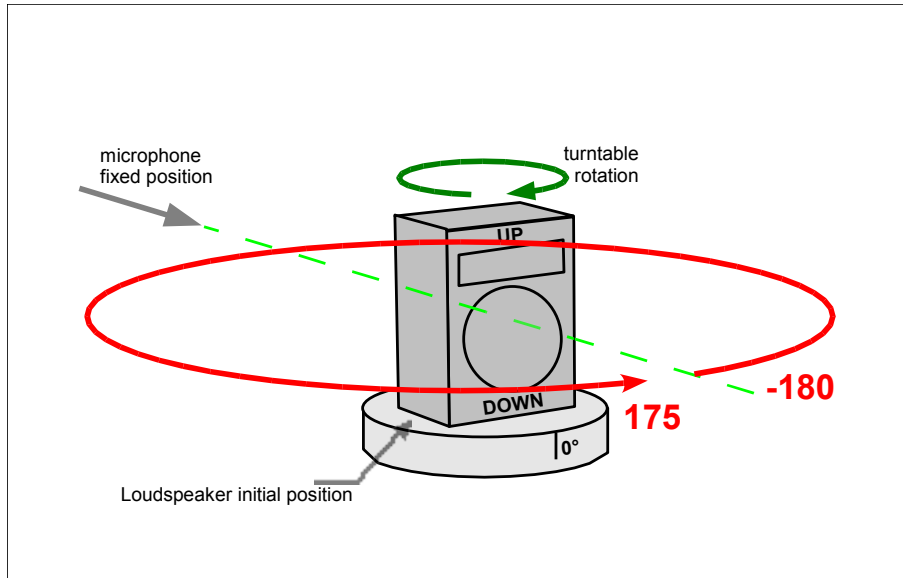

figure 1 - Horizontal Setup

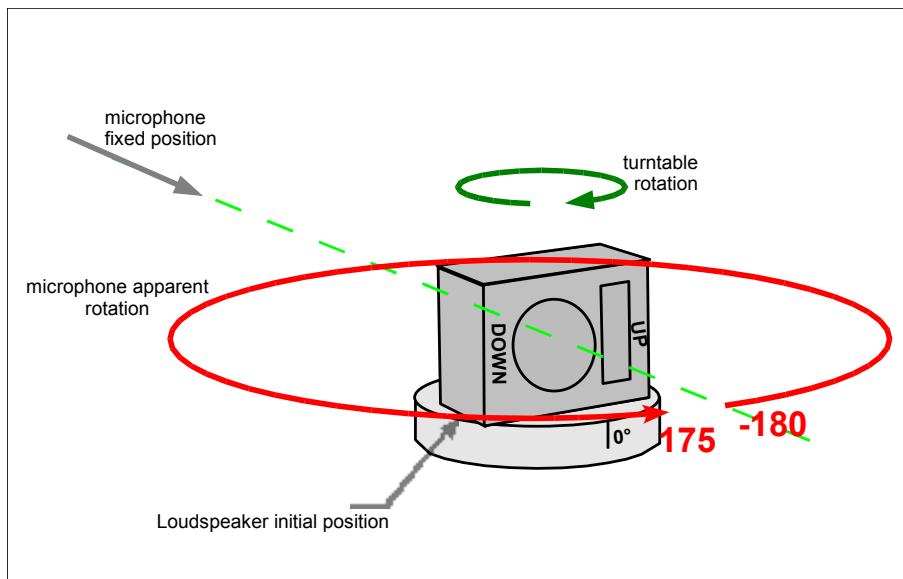

figure 2 - Vertical Setup

The sets can be easily made with a software controlled turntable and the CLIO autosave feature, starting with angle -180° and counting 72 measures with 5° step. The conversion software will read the “.mls” with the same windowing and smoothing functions applied in CLIO during the autosave procedure, set the smoothing on “unsmoothed”.

The use of the conversion software is easy, just enter the manufacturer and loudspeaker name, power handling and nominal impedance. Choose the horizontal and vertical data sets by selecting any file of the set, the software check if the data provided are complete. Then click on the “Create ASCII” button, after few seconds the ASCII will appear in the memo box. To save as a “.xhn” click the “Save as .xhn” button or copy the contents of the memo box into the notepad and, save as text file then replace the “.txt” extension with “.xhn”.

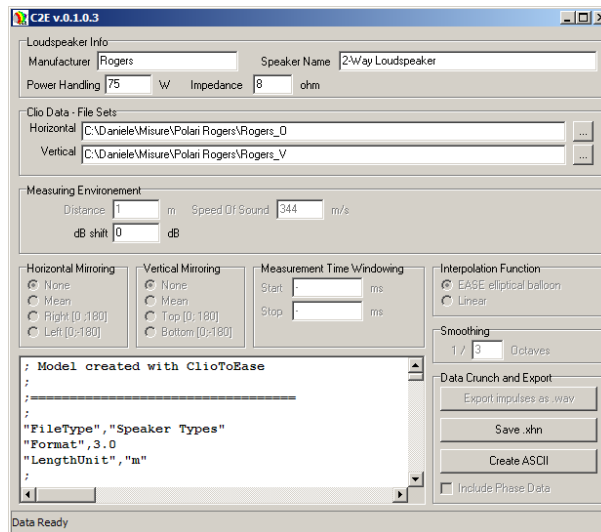

figure 3 - Converter Screenshot

Open EASE and import the ASCII “.xhn” file from the EASE loudspeaker base: File > Import ASCII. Choose a folder to store the model:

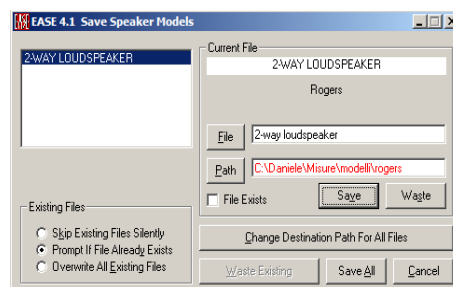

figure 4 - Speaker Model Save

At this point only attenuation data are loaded into the EASE loudspeaker model. If the speaker is supposed to be symmetric on the horizontal plane: Edit > Speaker Model.

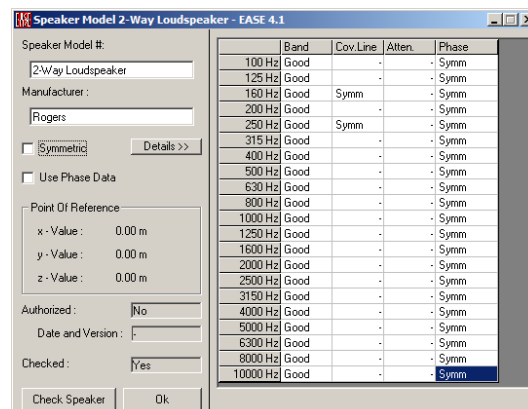

figure 5 - Speaker Model

Check the “Symmetric” box and follow the instructions, then click on the button “Check Speaker”.

The model must be completed by the calculation of the coverage cone, directivity and efficiency: Edit > Speaker Data or just press <F4>.

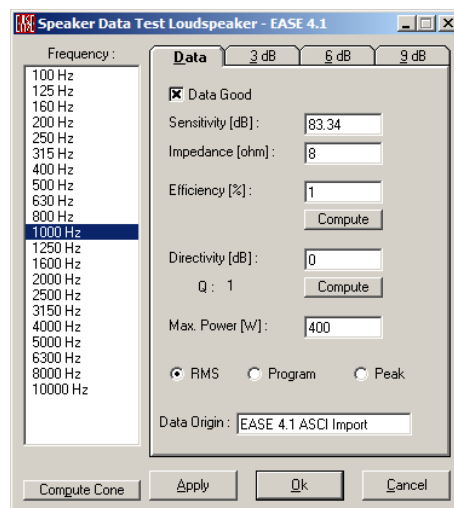
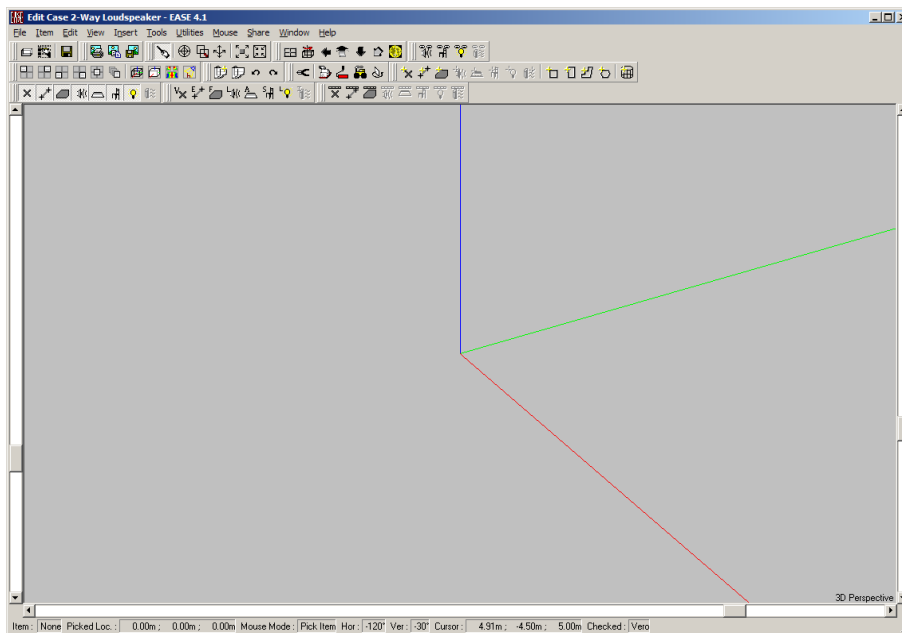

figure 6 - EASE Speaker Data

Click on “Compute Cone”, “Compute Directivity” and “Compute Efficiency” in this order, then click on “Apply”. At this point is it possible, if desired to draw the loudspeaker case: Edit > Case.



Is it possible to draw the case with faces or with edges. The reference point, the point used by EASE as a reference for all the simulation is 0,0,0 unless it is changed by the user inside the case edit by: Tools > Move Point of Reference. Since the position of the Point of Reference POR is relative to the case, it is not necessary to move the POR if we correctly draw the case around the POR.

In the loudspeaker of this example, the measurement setup is:

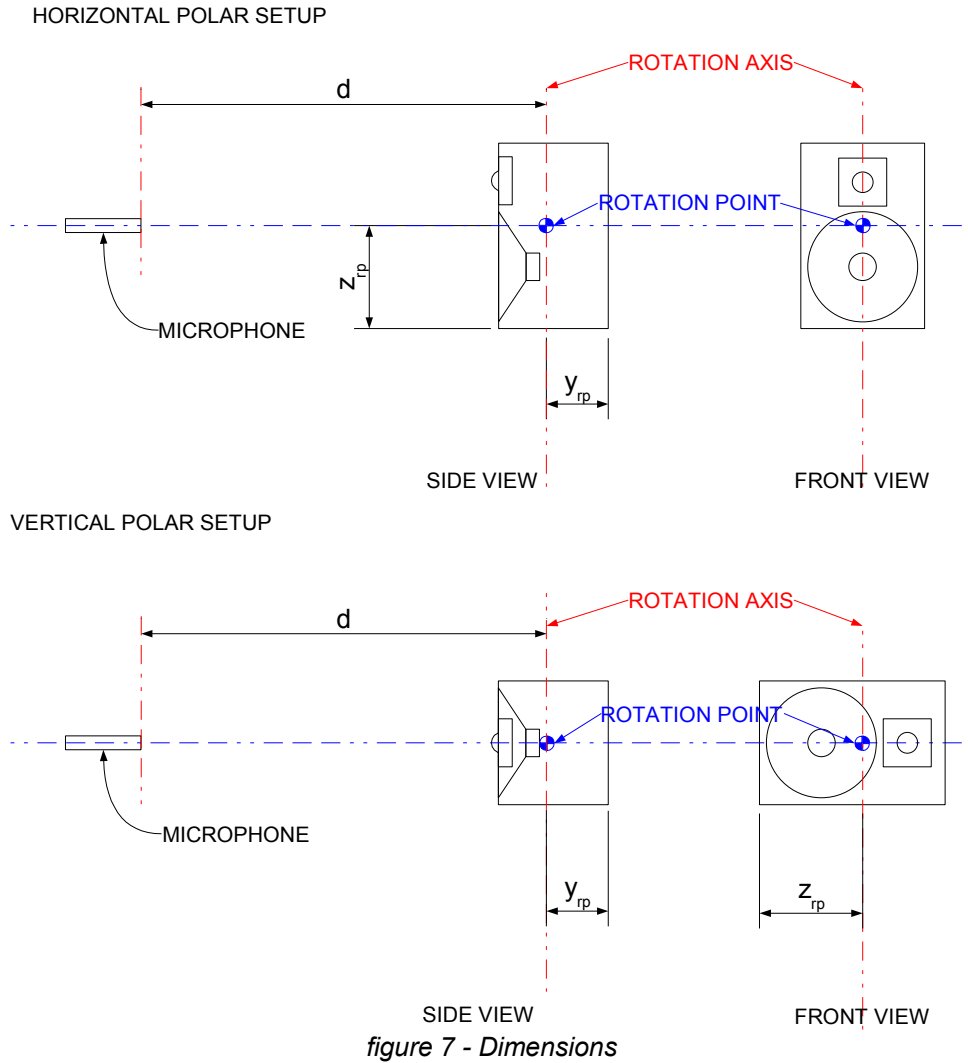

Where the cabinet dimensions are $H=30$ cm $W=19$ cm and $D=16$, the rotation point (called Point of Reference POR in EASE) position relative to the edge of the case, as in figure are $y_{rp}=8$ cm and $z_{rp}=15$ cm. Assuming that the 0,0,0 is the position of the POR the loudspeaker case design is straightforward:

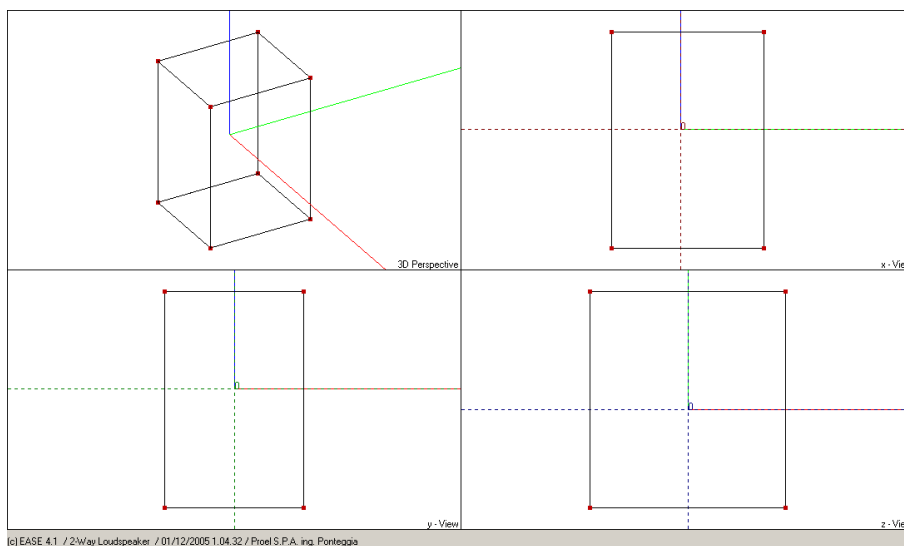

Source: 2-Way Loudspeaker ?
Manufacturer: Rogers
Attenuation Data
Paint Balloon :
Freq: 1000 Hz

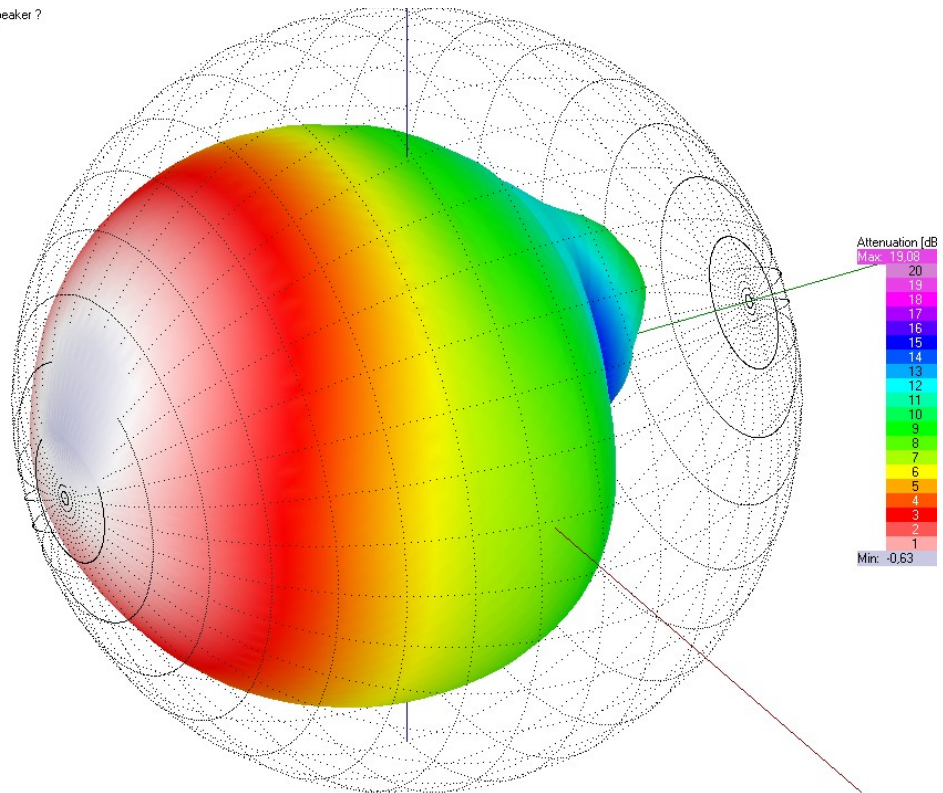

figure 9 - Attenuation Balloon

The model is complete and can be saved to be used into the simulation program. Here is an example of the loudspeaker model used into a room for acoustical coverage prediction:

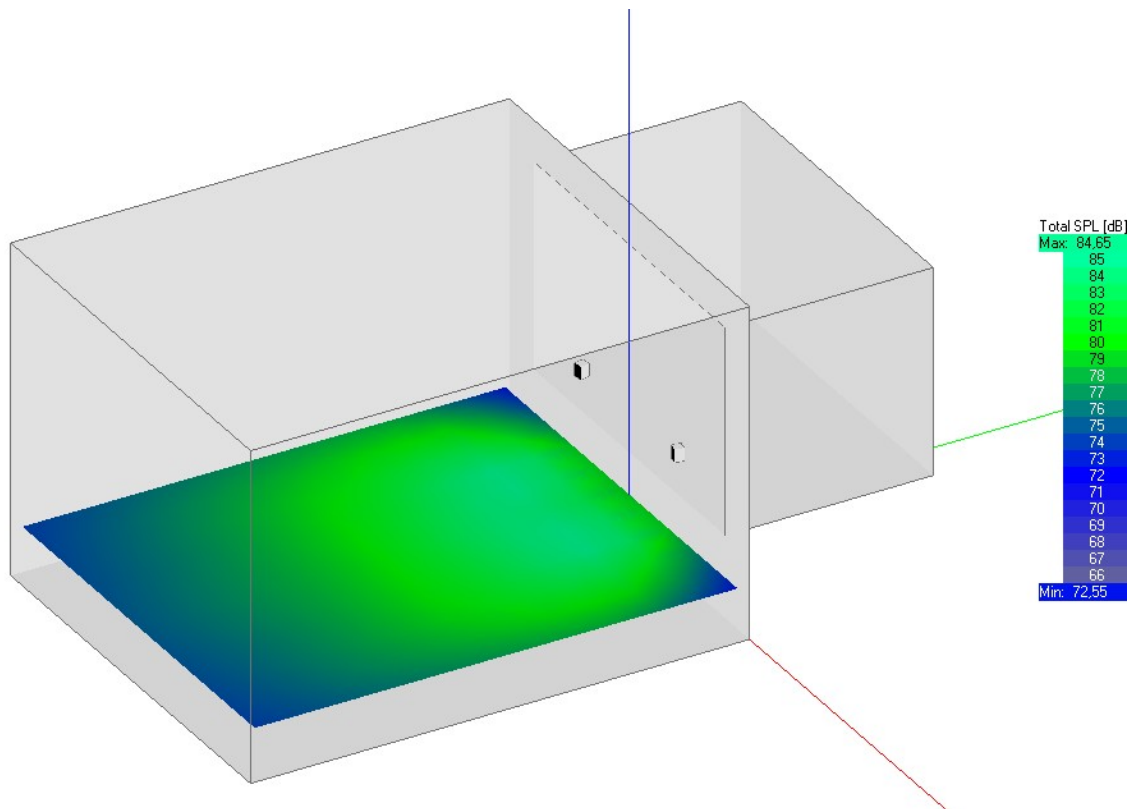

figure 10 - Simulated SPL in Room